

# M4-SERIES CONTROLLER ETHERNET CARD INSTALLATION GUIDE

Form 1156-190730–July 2019

**OPTO 22**  
The Future of Automation.

43044 Business Park Drive • Temecula • CA 92590-3614  
Phone: 800-321-OPTO (6786) or 951-695-3000  
Fax: 800-832-OPTO (6786) or 951-695-2712  
[www.opto22.com](http://www.opto22.com)

Product Support Services  
800-TEK-OPTO (835-6786) or 951-695-3080  
Fax: 951-695-3017  
Email: [support@opto22.com](mailto:support@opto22.com)  
Web: [support.opto22.com](http://support.opto22.com)

M4-Series Controller Ethernet Card Installation Guide  
Form 1156-190730—July 2019

Copyright © 1999–2019 Opto 22.

All rights reserved.

Printed in the United States of America.

All rights reserved.

Printed in the United States of America.

The information in this manual has been checked carefully and is believed to be accurate; however, Opto 22 assumes no responsibility for possible inaccuracies or omissions. Specifications are subject to change without notice.

Opto 22 warrants all of its products to be free from defects in material or workmanship for 30 months from the manufacturing date code. This warranty is limited to the original cost of the unit only and does not cover installation, labor, or any other contingent costs. Opto 22 I/O modules and solid-state relays with date codes of 1/96 or later are guaranteed for life. This lifetime warranty excludes reed relay, SNAP serial communication modules, SNAP PID modules, and modules that contain mechanical contacts or switches. Opto 22 does not warrant any product, components, or parts not manufactured by Opto 22; for these items, the warranty from the original manufacturer applies. These products include, but are not limited to, OptoTerminal-G70, OptoTerminal-G75, and Sony Ericsson GT-48; see the product data sheet for specific warranty information. Refer to Opto 22 form number 1042 for complete warranty information.

---

Opto 22 FactoryFloor, Cyrano, Optomux, and Pamux are registered trademarks of Opto 22. Generation 4, ioControl, ioDisplay, ioManager, ioProject, ioUtilities, mistic, Nvio, Nvio.net Web Portal, OptoConnect, OptoControl, OptoDisplay, OptoENETSniff, OptoOPCServer, OptoScript, OptoServer, OptoTerminal, OptoUtilities, SNAP Ethernet I/O, SNAP I/O, SNAP OEM I/O, SNAP Simple I/O, SNAP Ultimate I/O, and SNAP Wireless LAN I/O are trademarks of Opto 22.

ActiveX, JScript, Microsoft, MS-DOS, VBScript, Visual Basic, Visual C++, and Windows are either registered trademarks or trademarks of Microsoft Corporation in the United States and other countries. Linux is a registered trademark of Linus Torvalds. Unicenter is a registered trademark of Computer Associates International, Inc. ARCNET is a registered trademark of Datapoint Corporation. Modbus is a registered trademark of Schneider Electric. Wiegand is a registered trademark of Sensor Engineering Corporation. Nokia, Nokia M2M Platform, Nokia M2M Gateway Software, and Nokia 31 GSM Connectivity Terminal are trademarks or registered trademarks of Nokia Corporation. Sony is a trademark of Sony Corporation. Ericsson is a trademark of Telefonaktiebolaget LM Ericsson.

All other brand or product names are trademarks or registered trademarks of their respective companies or organizations.

# Table of Contents

Introduction .....	1
What's in this Guide .....	1
For Help .....	1
Description .....	2
Software .....	2
Firmware .....	3
Differences from Previous M4-Series Ethernet Cards .....	3
System Architecture .....	4
Connecting Directly .....	4
Attaching to a Standard Network .....	5
Installing the M4SENET-100 .....	6
Preparing the Card for Installation .....	6
Preparing the Controller for Installation .....	7
Inserting the Card in an M4-Series Controller (except SNAP-LCM4) .....	8
Inserting the Card in a SNAP-LCM4 Controller .....	9
Assigning an IP Address .....	10
Configuring the Controller in OptoControl for Ethernet .....	13
Configuring Security for the M4SENET-100 .....	14
Maintaining the M4SENET-100 .....	16
Changing or Viewing the IP Address .....	17
Operation Code Method .....	17
Jumper Method .....	19
Resetting the Card to Factory Defaults .....	20
Downloading New Firmware to the Card .....	20
Operation Code Method .....	21
Jumper Method .....	22
Specifications .....	24
LED Descriptions .....	24
M4SENET-100 Cover Plate .....	25
Troubleshooting .....	25
Serial or ARCNET Communication .....	25
Ethernet Communication .....	25
Ping the Card .....	26
Access the Card Using Telnet .....	27
Ethernet Session Information .....	27

TCP Settings .....	28
Blink Codes .....	29

# M4-Series Controller Ethernet Card Installation Guide

## INTRODUCTION

The M4SENET-100 is an Ethernet network interface card designed for Opto 22's legacy M4-series industrial controllers, such as the SNAP-LCM4 and the M4RTU. The key advantage of the M4SENET-100 is that it operates on standard Ethernet networks using standard TCP/IP transport. A separate I/O or control network is not required for the control system. (Note: M4-series controllers are legacy products and not recommended for new development. For new development, use SNAP PAC programmable automation controllers.)

### What's in this Guide

This guide assumes that you have some familiarity with TCP/IP and Ethernet networking. If you do not, we strongly suggest you consult commercially available resources to learn about these topics before attempting to install or use the M4SENET-100 interface card.

This guide describes the card and how to install it, tells how to use Telnet for diagnostics and configuring security, and includes maintenance and troubleshooting information. Specifications are on [page 24](#).

### For Help

If you have problems installing or using the M4SENET-100 interface card and cannot find the help you need in this guide or on our Web site, contact Opto 22 Product Support.

**Phone:** 800-TEK-PTO (800-835-6786 toll-free  
in the U.S. and Canada)  
951-695-3080  
Monday through Friday,  
7 a.m. to 5 p.m. Pacific Time

*NOTE: Email messages and phone calls to Opto 22 Product Support are grouped together and answered in the order received.*

**Fax:** 951-695-3017

**Email:** [support@opto22.com](mailto:support@opto22.com)

**Opto 22 website:** [www.opto22.com](http://www.opto22.com)

When calling for technical support, be prepared to provide the following information about your system to the Product Support engineer:

- Software and version being used
- Controller firmware version
- PC configuration
- A complete description of your hardware and operating systems, including:

- switch configuration
- type of power supply
- types of I/O units installed
- third-party devices installed (for example, barcode readers)
- Specific error messages seen.

## DESCRIPTION

The M4SENET-100 network interface card gives you the ability to connect an Opto 22 M4-series controller with a 10Base-T or 100Base-TX Ethernet network. The card can be used:

- as an I/O interface with Opto 22 SNAP Ethernet I/O units
- as a host interface with the Opto 22 FactoryFloor® software suite
- for peer-to-peer communication between controllers.

The M4SENET-100 automatically detects network speed and a half- or full-duplex environment. Since the card uses TCP/IP transport for all transactions, you can use it in switched, routed, bridged, or wide-area networks without special equipment.

As the following diagram shows, the M4SENET-100 includes a standard RJ-45 female connector for Ethernet communications. The card also has an auxiliary RS-232 serial port for maintenance.

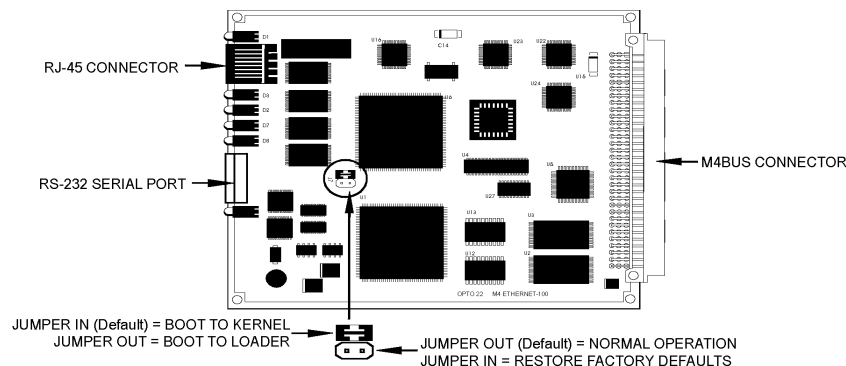

In addition, the card can be easily configured and diagnosed using Telnet.

## Software

The M4SENET-100 interface card is designed to work with FactoryFloor version 3.0 or higher. FactoryFloor is Opto 22's legacy suite of 32-bit industrial automation software for Microsoft® Windows®. FactoryFloor consists of the following integrated components:

- OptoControl™, a graphical, flowchart-based development environment for machine control and process applications
- OptoDisplay™, an intuitive, shared database, human-machine interface (HMI) and trending package, including alarming
- OptoServer™, an OPC-compliant data server that connects the controller network with the PC network

*NOTE: The M4SENET-100 card requires FactoryFloor release 3.0 or higher.*

## Firmware

The M4SENET-100 card comes with firmware already installed. However, you may have to upgrade firmware for the controller in which you install the card. The card requires a version 3.0 or higher Opto 22 kernel in the controller. Instructions for updating the firmware are on [page 7](#).

## Differences from Previous M4-Series Ethernet Cards

The M4SENET-100 differs from previous Ethernet cards used with M4-series controllers as follows:

- The M4SENET-100 is far faster than previous cards (100 Mbps rather than 10 Mbps).
- The M4SENET-100 can be easily diagnosed and maintained using Telnet.
- Previous cards supported both NetBIOS and TCP/IP; the M4SENET-100 supports TCP/IP only.
- The M4SENET-100 card requires FactoryFloor version 3.0 or greater. FactoryFloor 3.0 and above do not support the older M4SENETU or M4SENETC Ethernet cards.

## SYSTEM ARCHITECTURE

The M4SENET-100 card and its M4-series controller can be used in two ways:

- Connected directly to a PC or to a SNAP Ethernet brain and I/O unit
- Attached to a standard TCP/IP Ethernet network.

### Connecting Directly

A direct connection using an Ethernet crossover cable connects an M4SENET-100-equipped controller with just one PC or one SNAP Ethernet brain and I/O unit. A direct connection is useful for maintenance and troubleshooting.

The following diagrams show examples of a direct connection:

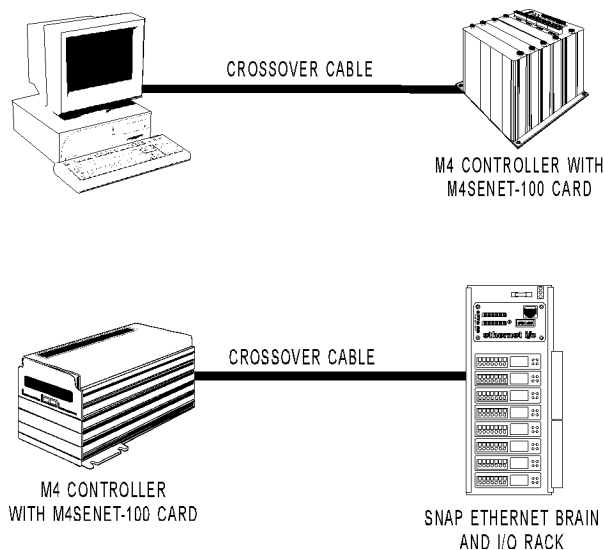

Use an Ethernet crossover cable for direct connections. The crossover cable must be a minimum of one meter long. (Maximum length is 100 meters.) For reliability, we recommend you purchase the cable rather than build it. You can purchase Ethernet crossover cables from most suppliers who carry standard Ethernet cables.

If you build your own crossover cable, you'll need an RJ-45 male connector at each end and solid category 5 unshielded twisted-pair cable. The cable includes four twisted pairs. Follow the illustration below for wiring the connectors.

*NOTE: The illustration below shows both a straight-through cable and a crossover cable. The straight-through cable is used for connecting the card to a hub on a standard Ethernet network. The crossover cable is used for direct connection to a PC or other host.*



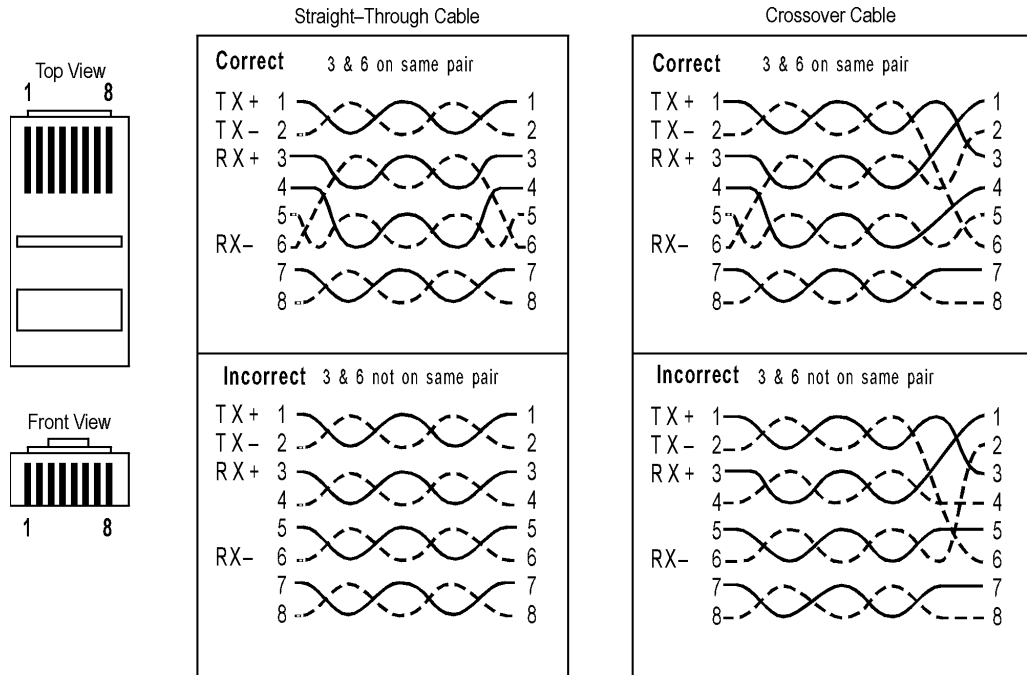

*NOTE: Make sure you put 3 and 6 on the same pair, or you may experience noise and distance limitations. Also make sure to include all pairs, since they are required for 100 Mbps.*

## Attaching to a Standard Network

The first rule when attaching to a standard Ethernet network is to work closely with your system administrator, who must determine network topology and hardware. Physical network configuration follows the 10Base-T and 100Base-TX standards. The network uses a star topology with a maximum hub-to-M4SENET-100 distance of 100 meters using solid category 5 or better unshielded twisted-pair cable.

In addition, make sure the system administrator understands that each M4SENET-100 card must have a **fixed (static)** IP address, whether or not a Dynamic Host Configuration Protocol (DHCP) server is active on the network.

The following diagram shows a sample network configuration using the M4SENET-100:

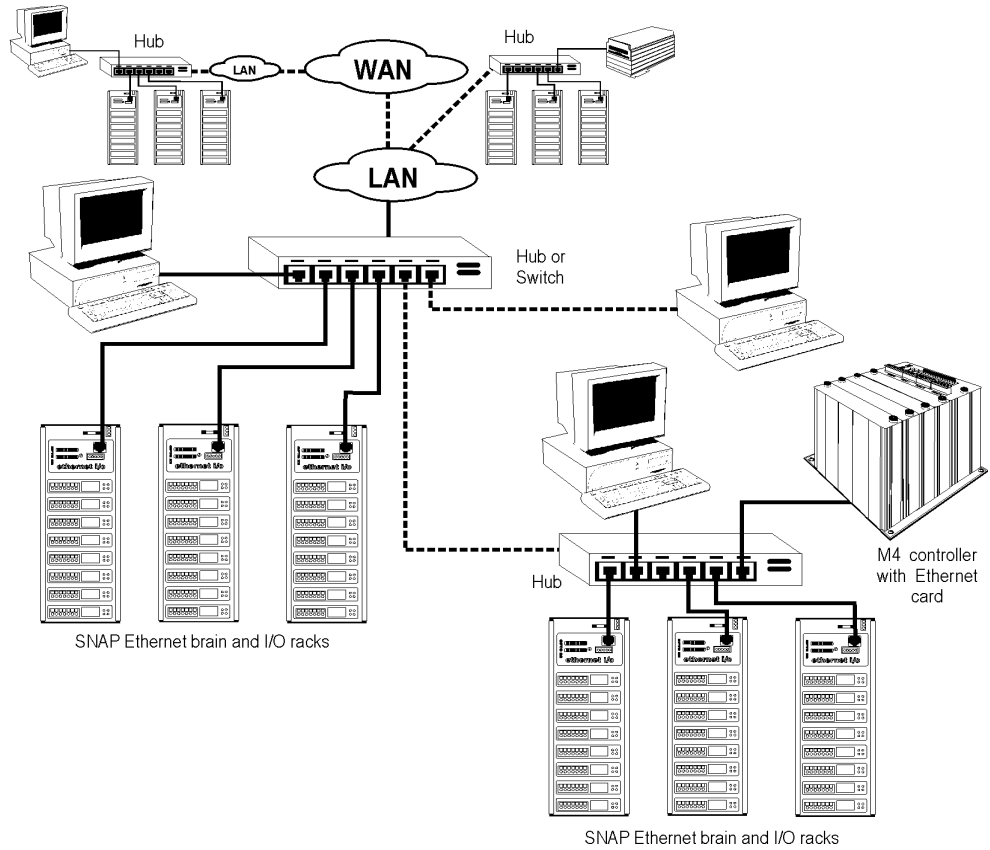

## INSTALLING THE M4SENET-100

### Preparing the Card for Installation

You can install only one M4SENET-100 card in each M4-series controller. Additional cards are not recognized. Before installing the M4SENET-100, write down its unique hardware (MAC) address, which is shown on a small white label on the card. The MAC address also appears on a larger label that comes in the box with the card. You will need the MAC address to assign an IP address to the card for Ethernet communication.

## Preparing the Controller for Installation

The M4SENET-100 card requires OptoKernel 3.0 or higher firmware in the controller. To find out what firmware release your controller has, follow these steps. If you do not have the correct firmware, you can download it from our Web site at [www.opto22.com](http://www.opto22.com).

*NOTE: On older controllers (controllers with a loader version lower than R4.1a), firmware cannot be downloaded to the controller using the Ethernet connection. Before you install the card, use a serial or ARCNET connection to check the firmware and loader versions. (The OptoEnet utility used with older Ethernet cards has been replaced with new software.)*

1. Connect the PC running FactoryFloor to the controller via the serial port (usually COM0).  
You can also use ARCNET if the controller has an ARCNET card.
2. Choose Start > Programs > Opto 22 > OptoUtilities > OptoTerm.
3. In the OptoTerm main window, double-click the name of the controller. (If the controller is not listed, add it by following the directions in Opto 22 form #724, the *OptoControl User's Guide*.)
4. In the Inspect Controller dialog box, look for the firmware version.

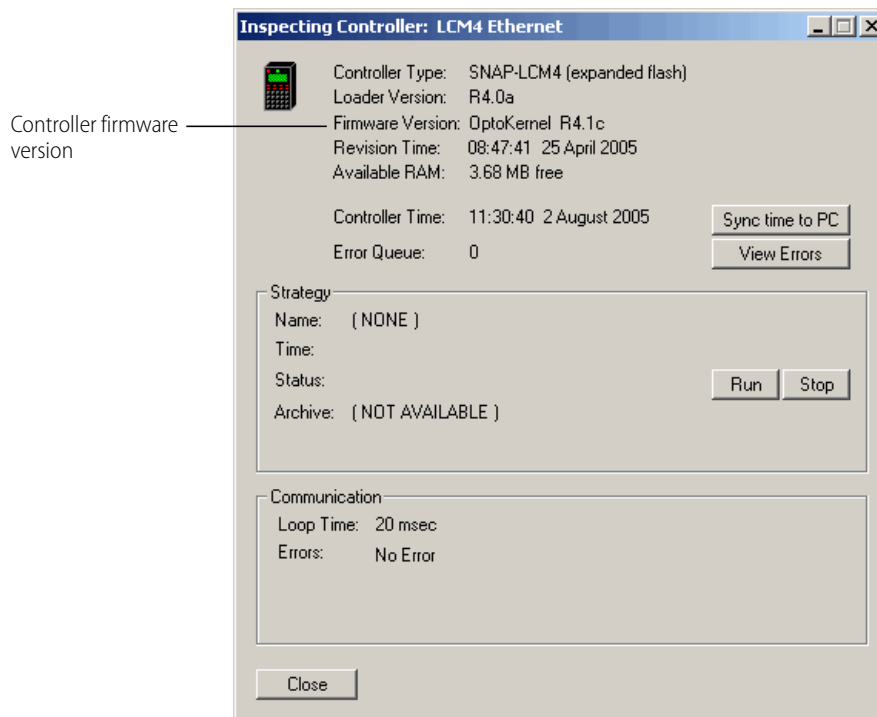

5. If the version is 3.0 or higher, exit OptoTerm. Skip the rest of the steps in this section and go to the steps for inserting the card ([page 9](#) for a SNAP-LCM4, or [page 8](#) for any other M4-series controller).
6. If the firmware version is lower than 3.0, close the Inspect Controller dialog box. In the main OptoTerm window, right-click the controller name and choose Download > Controller Kernel from the pop-up menu.
7. In the Open dialog box, locate your OptoKernel directory (C:\Opto22\OptoKrn1, by default). Click Files of Type and choose the name of your controller from the list. When the correct firmware file for your controller appears, double-click the file name.
8. When the full path to the correct file appears in the Download File dialog box, click OK.  
The firmware download begins, and a dialog box shows its progress.
9. When the download has finished, exit OptoTerm.

### Inserting the Card in an M4-Series Controller (except SNAP-LCM4)

*CAUTION: Once the M4SENET-100 card is installed in the controller, you will not be able to communicate with the controller by any method (even serial or ARCNET, regardless of host jumper settings) until you have also assigned the card a valid IP address and restarted the controller. At that time the card will send a startup packet to the controller, and the controller will be available for communication.*

1. Turn off the controller.
2. Select an unused M4BUS expansion slot, and remove its end cap. Save the screws.

As shown in the illustration below, end caps are located below the serial connectors. Each end cap is held in place by two screws located on the side panel, adjacent to each end cap. To correctly align the interface card, you may need to remove additional end caps from the controller.

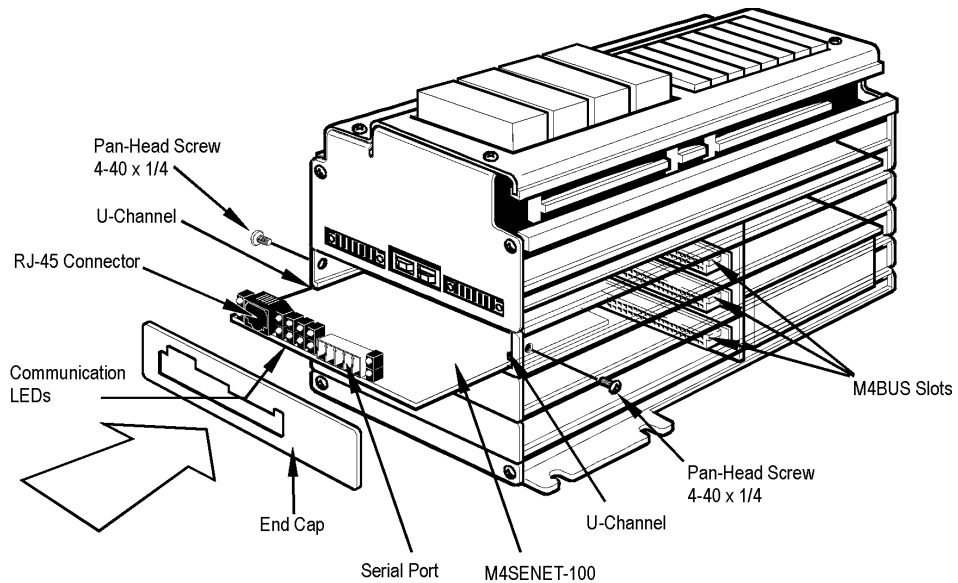

3. Align the edges of the M4SENET-100 card with the U-channels on the sides of the selected expansion slot, and then slide the card in until it is seated firmly in the M4BUS connector.
4. Use the screws from the original end cap to attach the included M4SENET-100 end cap to the M4-family controller.
5. Using the appropriate cable, connect the M4 controller to an Ethernet network.
6. If the M4SENET-100 will be used for host port communication, set the M4 controller's jumpers for Ethernet as shown in the table below.

	HO	H1
COM0	In	In
COM1	Out	In
ARCNET	In	Out
Ethernet	Out	Out

7. Follow the steps on [page 10](#) for assigning an IP address.

### Inserting the Card in a SNAP-LCM4 Controller

*CAUTION: Once the M4SENET-100 card is installed in the controller, you will not be able to communicate with the controller by any method (even serial or ARCNET, regardless of host jumper settings) until you have also assigned the card a valid IP address and restarted the controller. At that time the card will send a startup packet to the controller, and the controller will be available for communication.*

1. Turn off the controller.
2. Select an unused M4BUS expansion slot and remove its cover plate. Save the thumbscrews.

As shown in the illustration below, cover plates are located to the left of the serial connectors on the top of the SNAP-LCM4. Each cover plate is held in place by two thumbscrews.

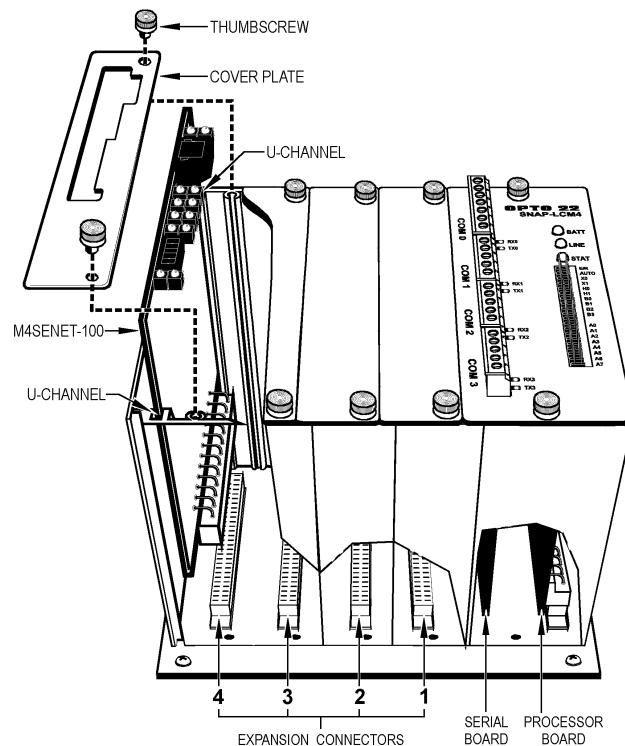

3. Align the edges of the M4SENET-100 card with the U-channels on the sides of the selected expansion slot, and then slide the card in until it is seated firmly in the M4BUS connector.
4. Use the thumbscrews from the original cover plate to attach the included M4SENET-100 cover plate to the SNAP-LCM4 controller.
5. Using the appropriate cable, connect the SNAP-LCM4 controller to an Ethernet network.
6. If the M4SENET-100 will be used for host port communication, set the LCM4 controller's jumpers for Ethernet as shown in the table at right.
7. Follow the steps in the next section for assigning an IP address.

**Host Port Jumpers**

	HO	H1
COM0	In	In
COM1	Out	In
ARCNET	In	Out
Ethernet	Out	Out

## Assigning an IP Address

Each M4SENET-100 card ships from the factory with a unique hardware Media Access Control (MAC) address and with an IP address of 0.0.0.0. This IP address is invalid. You or your network administrator must assign the card a valid IP address and subnet mask so it can communicate on the network.

Work with your network administrator to determine a compatible IP address and subnet mask, keeping the following requirements in mind:

- The IP address must be a **unique, fixed address** (not dynamically assigned).
- It must be compatible with the address and subnet mask configuration of the network card on the computer that will communicate with it. The IP address and subnet mask assigned to the M4SENET-100 card is compatible when it has a unique IP address on the same subnet as the network adapter of the PC.

In addition, you'll need to review these questions:

- Does your computer have multiple network adapters? You'll need to disable all the network adapters, except the one you are connecting to the M4SENET-100 card to assign it an IP address. You'll do this as the first step in the procedure (below).
- Does your network have a DHCP server? If so, then you'll need to do the following:
  - Directly connect the PC's network adapter (the one you left enabled) to the M4SENET-100 card with a crossover cable.
  - If the PC's network adapter card is currently configured for DHCP, you will need to temporarily change its configuration to assign it a fixed IP address. Make sure the fixed IP address will be compatible with the settings you will assign to the M4SENET-100. The instructions in "[Procedure](#)" on [page 10](#) will let you know when you can return the configuration to DHCP.

After installing a new M4SENET-100 card into a controller, connecting it to an Ethernet network, and then turning on the controller, the M4SENET-100 card begins sending out BootP broadcasts to request an IP address. Run PAC Manager or ioManager to "listen" for BootP requests so that you can assign it a fixed IP address. You can assign a unique, fixed IP address with either of the following utilities:

- PAC Manager, which is available for free download at [www.opto22.com](http://www.opto22.com); for instructions, see form #1714, *Legacy Edition, PAC Manager User's Guide*.
- ioManager, a legacy software utility. (ioManager replaced the previous OptoEnet utility for assigning IP addresses to older Ethernet cards.)

### PROCEDURE

1. Disable all network adapters on the PC, except for the one you will use to assign an IP address to the M4SENET-100 card.
2. Choose Start > Programs > Opto 22 > ioProject Software > ioManager.  
The ioManager main window opens:

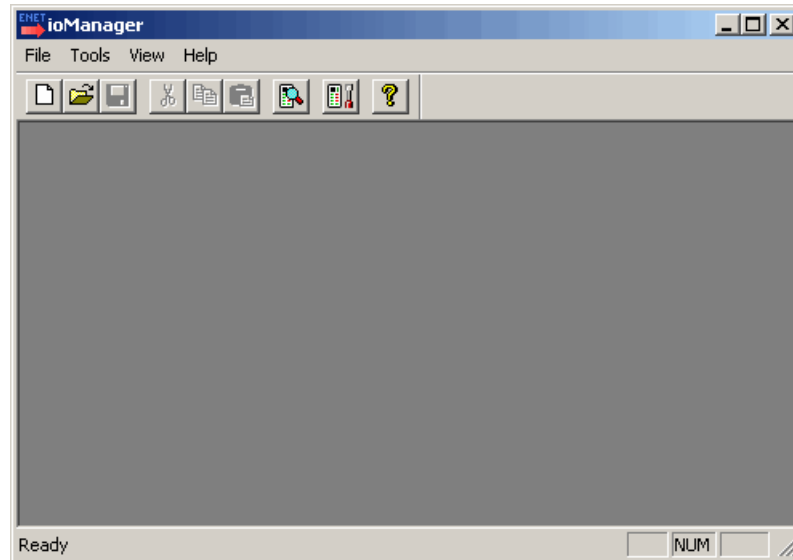

- From the Tools menu, choose Assign IP Address.

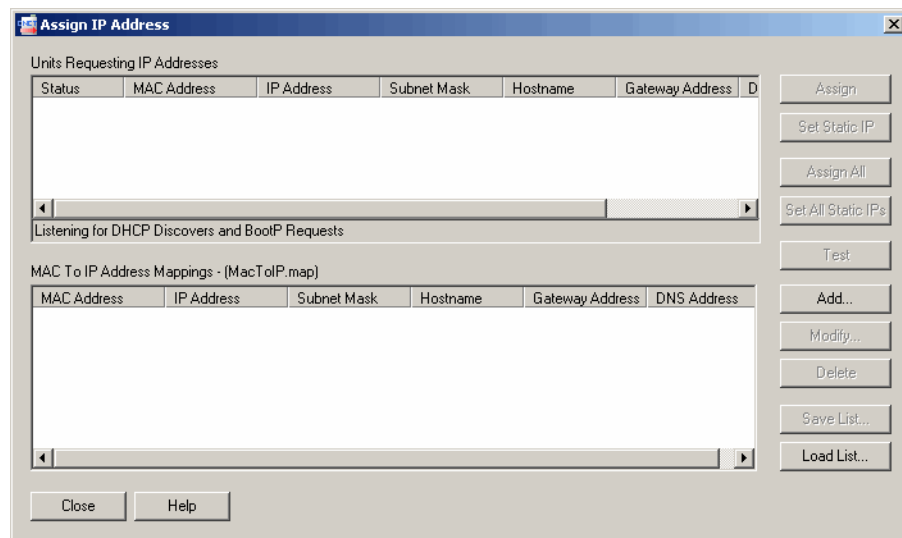

Any M4 controllers with M4SENET-100 cards (and any other Opto 22 Ethernet-based devices) without IP addresses that are on the PC's network segment will eventually appear (may take a few minutes) in the list of Units Requesting IP Address:

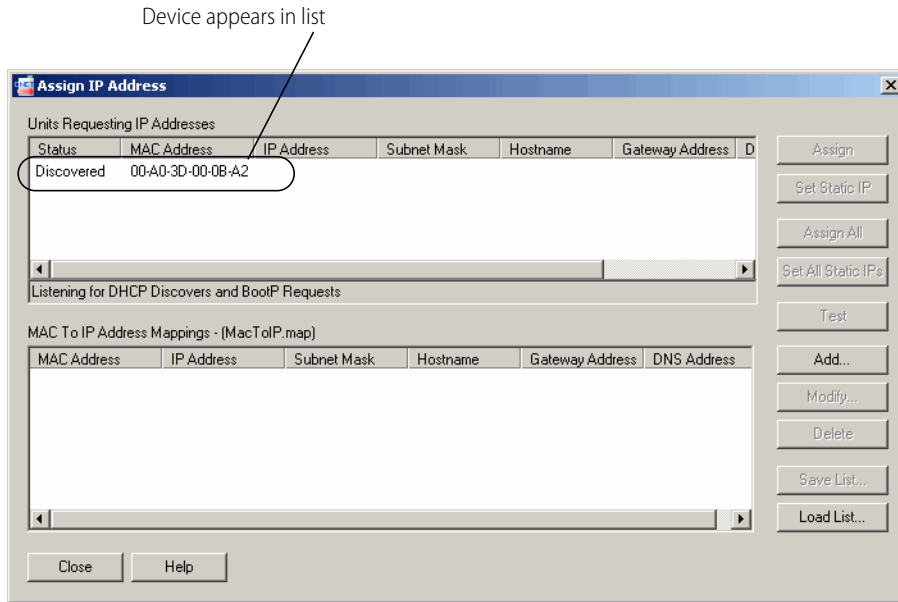

NOTE: If no MAC address appears, check the following:

- Is the card correctly connected to the PC? If the network has a DHCP server, then connect the M4SENET-100 directly to the PC with a crossover cable; otherwise, connect the M4SENET-100 to the network with a straight-through Ethernet cable.
  - Is the PC's network adapter on the same network as the card? See [page 4](#) and [page 10](#) for networking information.
  - Does the card already have an IP address? If you want to change the IP address, follow the instructions on [page 17](#).
  - Has the internal Boot to Kernel/Loader jumper been removed? If so, you must put it back in so the card boots to the kernel. See [page 16](#) for more information on internal jumpers.
  - Does the PC have firewall software that blocks network broadcasts? If so, temporarily disable the firewall.
4. Double-click the MAC address of the card in the list.

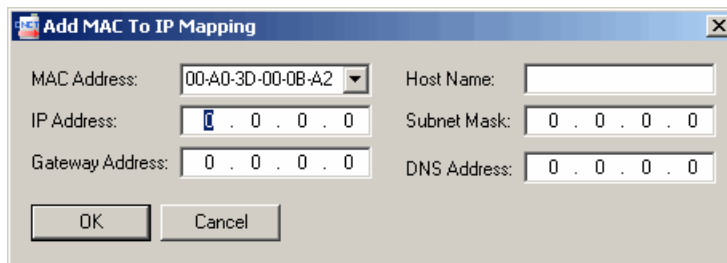

Enter the IP address and Subnet Mask for the card. If the card will also need to communicate with a device on another subnet, enter the gateway (router) address. If the card will talk only on the local subnet, leave the gateway address all zeros (0.0.0.0). Leave the DNS address field all zeros.

*WARNING: Each device on your network, including computers, routers, cards, and so on, must have a unique IP address. Failure to assign unique IP addresses may cause catastrophic network issues. If you don't know which IP addresses are safe to use, check with your system administrator.*



- When the IP address, subnet mask, and other fields are correct, click OK.  
The Status changes to Mapped in the upper list, and the device appears in the lower list:

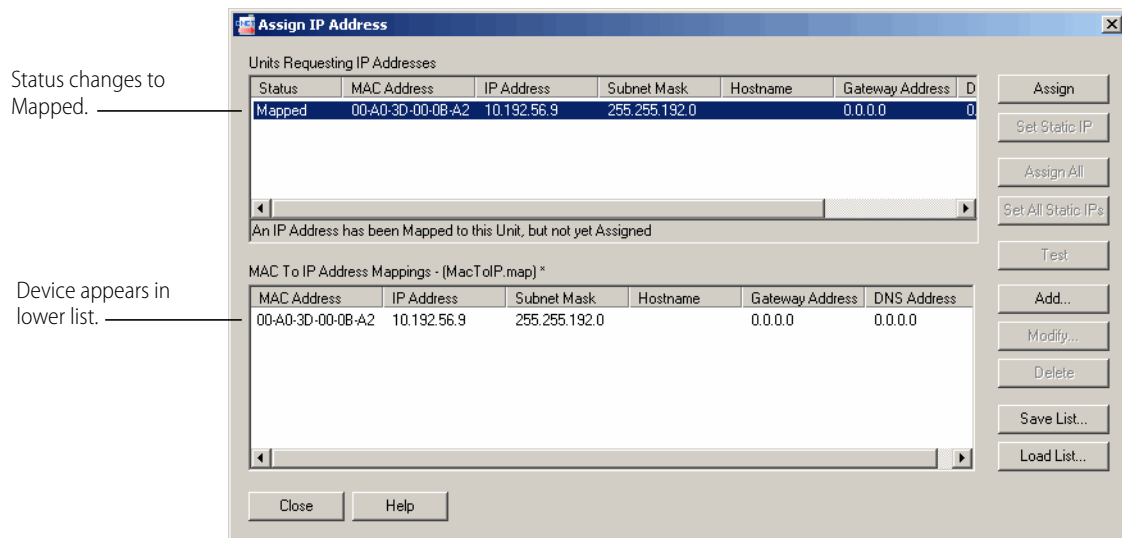

- To finish assigning the IP address, click Assign.  
The address information is sent to the card, and the Status changes to Static IP.
- To verify that the IP address has been successfully assigned, highlight the card in the upper list (Units Requesting IP Addresses) and click Test.  
A command prompt window opens and the IP address is automatically pinged. The card should reply. If it doesn't:
  - Make sure the IP address and subnet mask you've assigned is compatible with the IP address and the subnet mask of the network adapter on the PC. (See explanation on [page 10](#).)
  - Make sure you disabled the other network adapters on your PC. See [step 1 on page 10](#).
- Write the IP address for the card on the label provided and put it on the outside of the controller for future reference.
- Repeat steps 4 through 8 for any other cards in the list.
- After you have assigned IP addresses to all the cards, you can optionally save the lower list in a file for future reference by clicking Save List. Click Close.
- To complete the process, turn the controller(s) off and then back on again.
- If you disabled the Windows firewall or any of the other network adapters on the PC during this procedure, you can now re-enable those items.
- If you connected the M4SENET-100 to the computer with a crossover cable, now you can connect the computer back to the network again with the original (straight-through) cable. If you changed the PC's network adapter configuration from DHCP to a fixed IP address for this procedure, then restore it to DHCP.

## Configuring the Controller in OptoControl for Ethernet

After you have installed the M4SENET-100 card in the controller, connected it to the Ethernet network, and assigned the necessary IP address, you need to use OptoControl to configure the controller for Ethernet. To do so, follow the steps in the controllers chapter in the *OptoControl User's Guide*.

## CONFIGURING SECURITY FOR THE M4SENET-100

You can configure security on the M4SENET-100 card using a computer with Telnet. To use Telnet, you need to know the M4SENET-100's IP address. If the IP address has not yet been assigned, see [page 10](#) for instructions.

For configuration, it's usually best to connect the card to your PC via a crossover cable. (For help, see "Connecting Directly" on [page 4](#).) Once the PC and card are connected, follow these steps.

*NOTE: These steps assume you are running Windows and accessing Telnet from a command prompt. Other Telnet software will also work if you make sure that local echo is turned off; your steps may be slightly different.*

1. From the Start menu, choose Programs > Accessories > Command Prompt.
2. At the prompt, type `telnet` and the IP address of the M4SENET-100 interface card, and then press ENTER.

For example, if the card's IP address were 10.192.54.87, you would type

```
telnet 10.192.54.87
```

The M4-SENET-100 main menu appears:

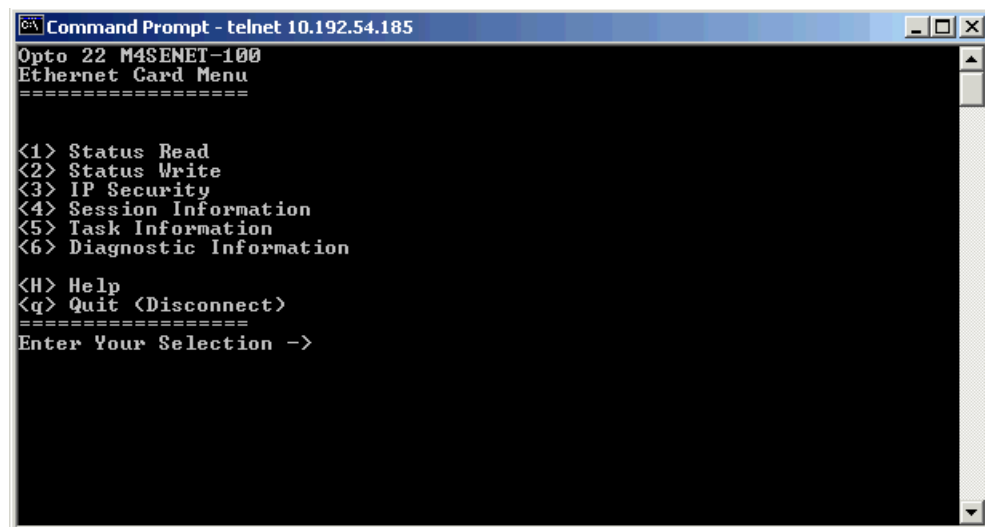
A screenshot of a Windows Command Prompt window titled "Command Prompt - telnet 10.192.54.185". The window displays the output of a Telnet connection to an M4SENET-100 Ethernet Card. The text shown is: "Opto 22 M4SENET-100 Ethernet Card Menu", followed by a list of menu options: "<1> Status Read", "<2> Status Write", "<3> IP Security", "<4> Session Information", "<5> Task Information", "<6> Diagnostic Information", "<H> Help", and "<q> Quit <Disconnect>". The prompt "Enter Your Selection ->" is visible at the bottom of the menu.

```
Command Prompt - telnet 10.192.54.185
Opto 22 M4SENET-100
Ethernet Card Menu
=====
<1> Status Read
<2> Status Write
<3> IP Security
<4> Session Information
<5> Task Information
<6> Diagnostic Information

<H> Help
<q> Quit <Disconnect>
=====
Enter Your Selection ->
```

- At the prompt in the main menu, type 3.

```

Command Prompt - telnet 10.192.54.185
Opto 22 M4SENET-100
IP Security
=====
0xFFFF F03A 0014 Telnet Server <default 23>      23
0xFFFF F03A 0070 Stop incoming broadcasts      No
0xFFFF F03A 0020 IP Filter 0 Address      0.0.0.0
0xFFFF F03A 0024 IP Filter 0 Mask      0.0.0.0
0xFFFF F03A 0028 IP Filter 1 Address      0.0.0.0
0xFFFF F03A 002C IP Filter 1 Mask      0.0.0.0
0xFFFF F03A 0030 IP Filter 2 Address      0.0.0.0
0xFFFF F03A 0034 IP Filter 2 Mask      0.0.0.0
0xFFFF F03A 0038 IP Filter 3 Address      0.0.0.0
0xFFFF F03A 003C IP Filter 3 Mask      0.0.0.0
0xFFFF F03A 0040 IP Filter 4 Address      0.0.0.0
0xFFFF F03A 0044 IP Filter 4 Mask      0.0.0.0
0xFFFF F03A 0048 IP Filter 5 Address      0.0.0.0
0xFFFF F03A 004C IP Filter 5 Mask      0.0.0.0
0xFFFF F03A 0050 IP Filter 6 Address      0.0.0.0
0xFFFF F03A 0054 IP Filter 6 Mask      0.0.0.0
0xFFFF F03A 0058 IP Filter 7 Address      0.0.0.0
0xFFFF F03A 005C IP Filter 7 Mask      0.0.0.0
0xFFFF F03A 0060 IP Filter 8 Address      0.0.0.0
0xFFFF F03A 0064 IP Filter 8 Mask      0.0.0.0
<B>ack      <R>efresh      <H>elp      <Q>Quit

```

You can set up security for the M4SENET-100 card by limiting access to the card based on the IP address of the computer or other host device attempting to communicate with the card. You specify the IP addresses that may access the card. Anyone on a computer or other host device with an acceptable IP address has access.

- To enter a filter address or filter mask, use the up or down arrows to move the cursor to the field you want to change. Press E to edit the field. Type the numbers, then press ENTER.

You can set up to nine filter addresses and filter masks. The filter address is the IP address that is allowed to access the card; the filter mask indicates a range of allowed addresses.

- If only one IP address may access the card, enter that address as the IP Filter Address and enter 255.255.255.255 for the Filter Mask.
- If up to nine varied IP addresses may access the card, enter each one in an IP Filter Address field and enter 255.255.255.255 for the Filter Mask for each one.
- If a range of IP addresses may access the card, enter a mask that reflects the subnet range.  
For example, if only IP address 1.2.3.4 may access the card, enter 1.2.3.4 as the filter address and 255.255.255.255 as the filter mask. If any IP address that starts with 1.2.3 may access the card, enter 1.2.3.4 (or 1.2.3.1, or any address in the range) as the filter address and 255.255.255.0 as the filter mask.

- When you have finished setting up security, press B to return to the main menu.
- In the main menu, enter 2 to go to the Status Write screen.

You must save security data to flash memory, or it will be lost when power to the card is turned off.

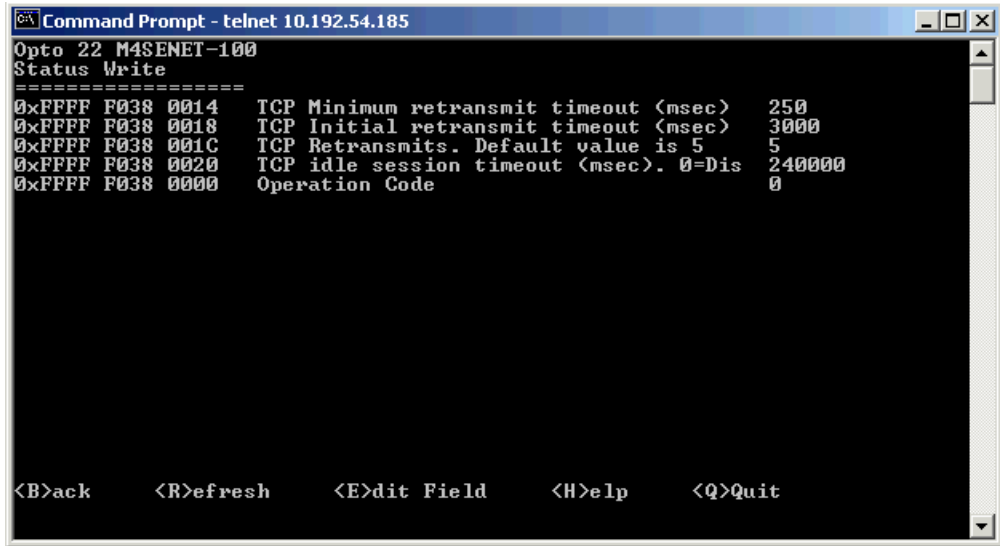

7. In the Status Write screen, use the down arrow key to move the cursor to the Operation Code field. Press E.
8. Type 3 in the Operation Code field.  
*CAUTION: Make sure you type 3. If you type the wrong number, you could erase flash or restart the card.*
9. Press ENTER.  
The security information is stored to flash memory.

## MAINTAINING THE M4SENET-100

The M4SENET-100 interface card includes two internal jumpers. **You will not normally need to change either of these jumpers.**

The following diagram shows jumper positions and functions:

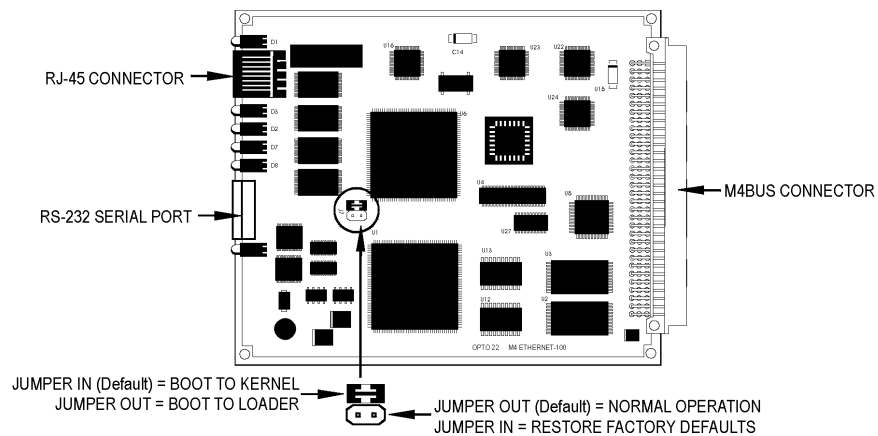

If you have problems with or questions about the internal jumpers, please contact Opto 22 Product Support. (See [page 1.](#))

Topics in this section:

- “Changing or Viewing the IP Address” (below)
- “Resetting the Card to Factory Defaults” on page 20
- “Downloading New Firmware to the Card” on page 20

### Changing or Viewing the IP Address

If you forget an M4SENET-100 card’s IP address, you can find out what it is using ioManager with a serial connection in loader mode. If necessary, you can also change the IP address or subnet mask of the card using ioManager.

You can put the card into loader mode either with an operation code in a telnet session or by removing a jumper. Follow the directions in *one* of the following sections:

- Operation Code Method (below)
- Jumper Method on page 19

#### Operation Code Method

This procedure describes how to use an operation code to put the card into loader mode and then view or change the IP address or subnet mask.

*NOTE: If you have an older M4SENET-100 card with a loader version lower than 2.0, we recommend using the jumper method on page 19. If you use the operation code method with an older loader, in order to return to kernel mode you may need to load new firmware on the card. To check the loader version, see step 4 below.*

1. Connect the card’s RS-232 port to the PC via serial cable, following the serial connection diagram at right.
2. From the Start menu, choose Programs > Accessories > Command Prompt.
3. At the prompt, type `telnet` and the IP address of the M4SENET-100 interface card, and then press ENTER.

For example, if the card’s IP address were 10.192.54.87, you would type  
`telnet 10.192.54.87`

The M4-SENET-100 main menu appears:

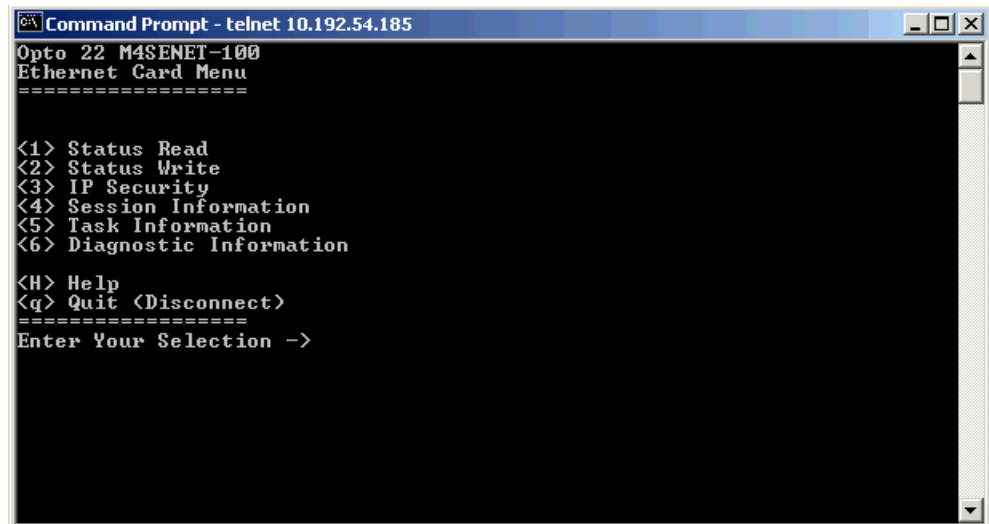
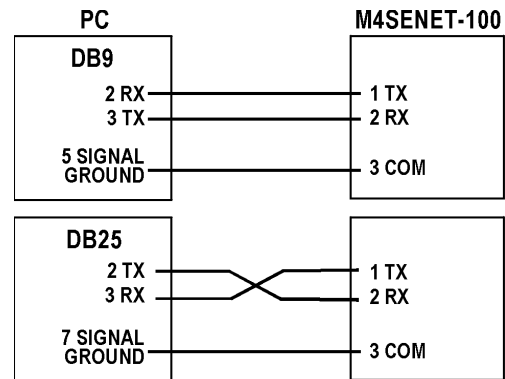

4. (Optional) If you want to check the loader version, enter 1 to open the Status Read screen. Press B to return to the main menu.
5. Enter 2 to open the Status Write screen.
6. In the Status Write screen, use the down arrow key to move the cursor to the Operation Code field. Press E.
7. Type 2271560481 (0x87654321 hex).

*CAUTION: Make sure you type the correct number. If you type the wrong number, you could erase flash or restart the card.*

8. Press ENTER.  
The M4SENET-100 card enters loader mode at this point and loses its Ethernet connection. The message, `connection to host lost`, appears within about one minute.
9. Choose Start > Programs > Opto 22 > ioProject Software > ioManager.
10. In the ioManager main window, choose Tools > Install Firmware via Serial Connection.  
The OptoFlashENET window opens:

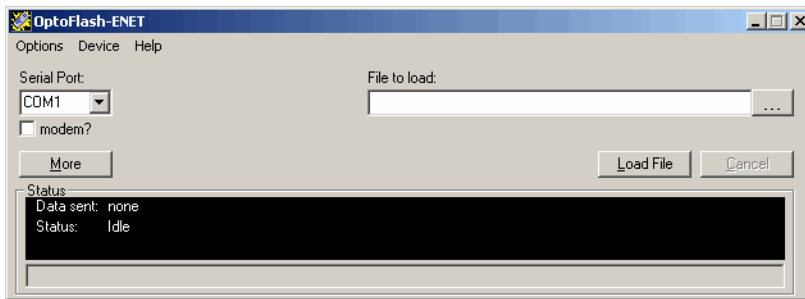

11. Make sure the COM port shown is the correct port on the PC. Choose Device > Serial Connection.  
The utility contacts the M4SENET-100 card and displays its IP address and subnet mask:

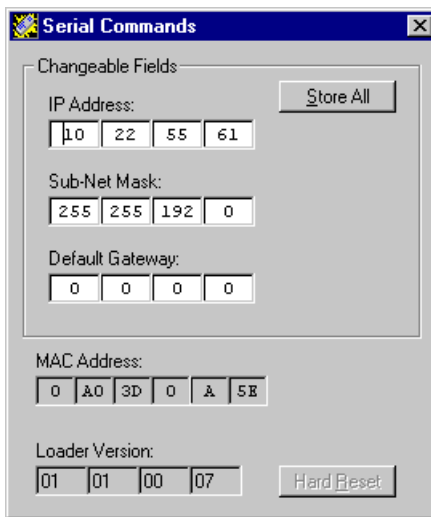

12. If you need to change the IP address or subnet mask, type in the new numbers. Make sure they are correct. Then click Store All.  
The new IP address and subnet mask are sent to the card.

- To return the card to normal operation, turn off the power to the controller and then turn it back on. If the card stays in loader mode after cycling the power, you may need to load new firmware. See [step 7](#) through [step 11](#) under “[Downloading New Firmware to the Card](#)” on [page 20](#).

**Jumper Method**

This procedure describes how to put the card into loader mode by removing a jumper and then view or change the IP address or subnet mask.

- Turn off the controller. Remove the Ethernet connector.
- Remove the cover plate for the M4SENET-100 card. **Carefully** remove the card.
- Remove the Boot to Kernel/Loader jumper. (See diagram on [page 16](#) for jumper location.)
- Carefully put the card back into the controller.
- Connect the card’s RS-232 port to the PC via serial cable, following the serial connection diagram at right.
- Turn the controller on.
- Choose Start > Programs > Opto 22 > ioProject Software > ioManager.
- In the ioManager main window, choose Tools > Install Firmware via Serial Connection.

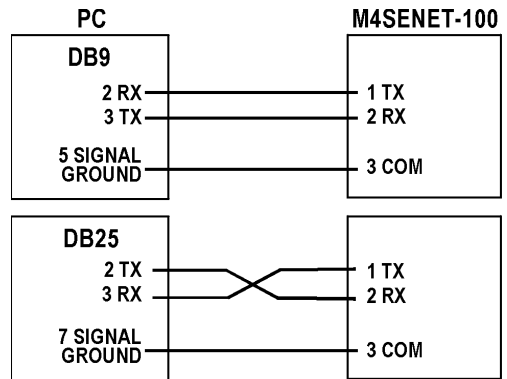

The OptoFlashENET window opens:

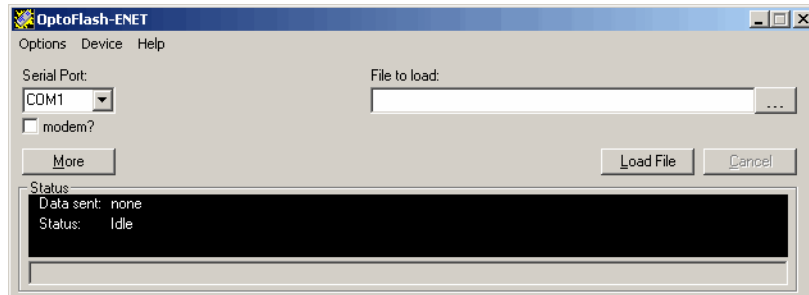

- Make sure the COM port shown is the correct port on the PC. Choose Device > Serial Connection. The utility contacts the M4SENET-100 card and displays its IP address and subnet mask:

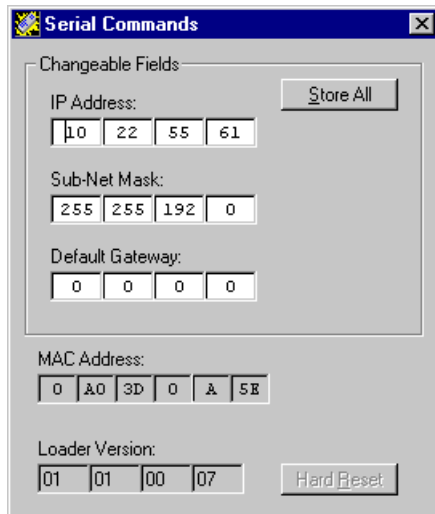

10. If you need to change the IP address or subnet mask, type in the new numbers. Make sure they are correct. Then click Store All.

The new IP address and subnet mask are sent to the card.

11. Turn off the controller. Remove the serial cable. Carefully remove the card.
12. Put the Boot to Kernel/Loader jumper back in.

*IMPORTANT: Make sure you put the correct jumper back in the card! The controller will not respond unless the card's Boot to Kernel/Loader jumper is in.*

13. Replace the card in the controller, replace its cover plate, and plug the Ethernet connector back in.
14. Turn on the controller.

### Resetting the Card to Factory Defaults

*CAUTION: Resetting to factory defaults resets the card's IP address to 0.0.0.0 and its subnet mask to 255.255.255.0. Use ioManager to reassign the IP address and subnet mask (page 10).*

1. Turn the controller off. Remove the card's cover plate. **Carefully** remove the card from the controller.
2. Put the Restore Factory Defaults jumper in. (See diagram on page 16 for jumper location.)
3. Carefully put the card back in the controller and turn the controller on.

The STD LED flashes rapidly for a brief period while the unit is restoring defaults. After this rapid flashing, on older cards (manufactured before August 2000), the LED stops blinking. On newer cards, the LED begins a repeated sequence of 14 blinks.

4. Wait a few seconds until the rapid flashing stops, and then turn the controller off.
5. Carefully remove the card and remove the jumper. Put the card back in the controller and replace its cover plate.
6. Before turning the controller on again, use ioManager to assign the correct IP address. (See page 10.)

### Downloading New Firmware to the Card

If the M4SENET-100's firmware should become damaged, or if you need to load a new version of the firmware to the card, you can do so by putting the card in loader mode and using ioManager to download the firmware.

*CAUTION: This procedure is for downloading new firmware to the card. To download firmware to the controller, see "Preparing the Controller for Installation" on page 7.*



You can put the card into loader mode either with an operation code in a telnet session or by removing a jumper. Follow the directions in *one* of the following sections:

- Operation Code Method (below)
- Jumper Method on [page 22](#)

**Operation Code Method**

This procedure describes how to use an operation code to put the card into loader mode and then download new firmware to the card.

*NOTE: If you have an older M4SENET-100 card with a loader version lower than 2.0, we recommend using the jumper method on [page 22](#). If you use the operation code method with an older loader, in order to return to kernel mode you may need to load new firmware on the card. To check the loader version, see [step 4](#) below.*

1. Connect the card's RS-232 port to the PC via serial cable, following the serial connection diagram at right.
2. From the Start menu, choose Programs > Accessories > Command Prompt.
3. At the prompt, type `telnet` and the IP address of the M4SENET-100 interface card, and then press ENTER.

For example, if the card's IP address were 10.192.54.87, you would type  
`telnet 10.192.54.87`

The M4-SENET-100 main menu appears:

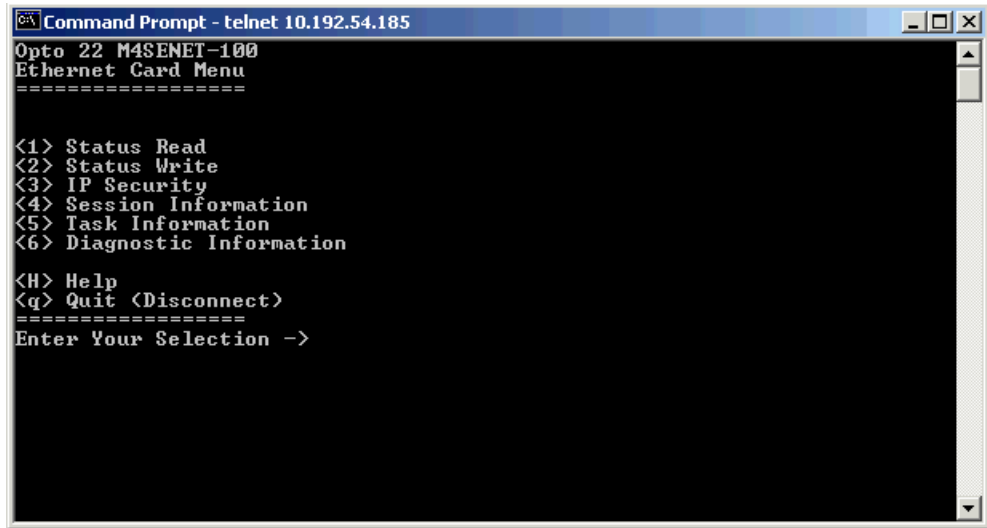
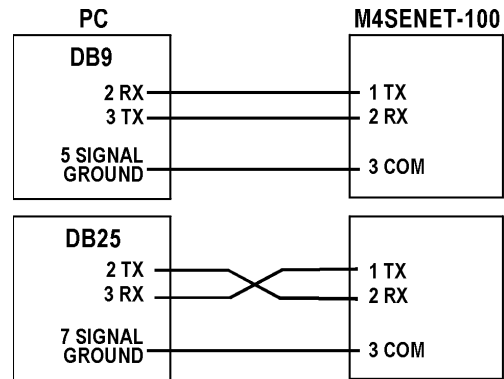

4. (Optional) If you want to check the loader version, enter 1 to open the Status Read screen. Press B to return to the main menu.
5. Enter 2 to go to the Status Write screen.
6. In the Status Write screen, use the down arrow key to move the cursor to the Operation Code field. Press E.
7. Type `2271560481` (0x87654321 hex).

*CAUTION: Make sure you type the correct number. If you type the wrong number, you could erase flash or restart the card.*

8. Press ENTER.  
The M4SENET-100 card enters loader mode at this point and loses its Ethernet connection. The message, `Connection to host lost`, appears after about one minute.
9. Choose Start > Programs > Opto 22 > ioProject Software > ioManager.
10. In the ioManager main window, choose Tools > Install Firmware via Serial Connection.
11. If you are using a serial connection to the M4SENET-100, choose the computer's Serial Port from the drop-down list and skip to [step 10](#).
12. If you are using modems to communicate with the M4SENET-100, check the modem box. If the phone number of the M4SENET-100's modem is shown, go on to [step 10](#). If the correct phone number is not shown, choose Options > Change Modem Options. In the dialog box, enter the M4SENET-100's modem phone number and click Close.
13. In the File to load field, type the location of the firmware file, or click the browse button to locate it.
14. When the correct file appears in the field, click Load File.  
The firmware is loaded to the card. The Status area shows its progress.
15. When the load is complete, turn off the controller, and then turn it back on.

If you have any difficulty obtaining or downloading new firmware, contact Opto 22 Product Support. See [page 1](#) for contact information.

**Jumper Method**

This procedure describes how to remove a jumper to put the card into loader mode and then download new firmware to the card.

1. Turn the controller off. Remove the card's cover plate. **Carefully** remove the card from the controller.
2. Remove the Boot to Kernel/Loader jumper. (See diagram on [page 16](#).)
3. Carefully replace the card in the controller.
4. Connect the card's RS-232 port to a PC via serial cable, following the serial connection diagram at right.
5. Turn the controller on.
6. Choose Start > Programs > Opto 22 > ioProject Software > ioManager.
7. In the ioManager main window, choose Tools > Install Firmware via Serial Connection.

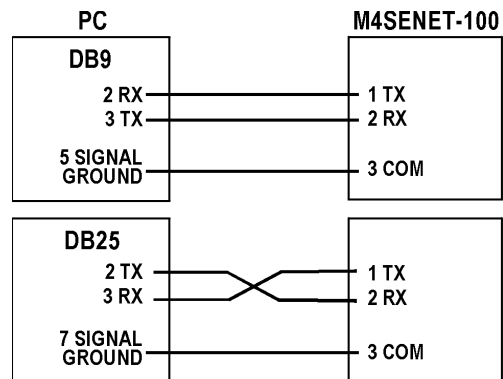

The OptoFlash-ENET main window appears:

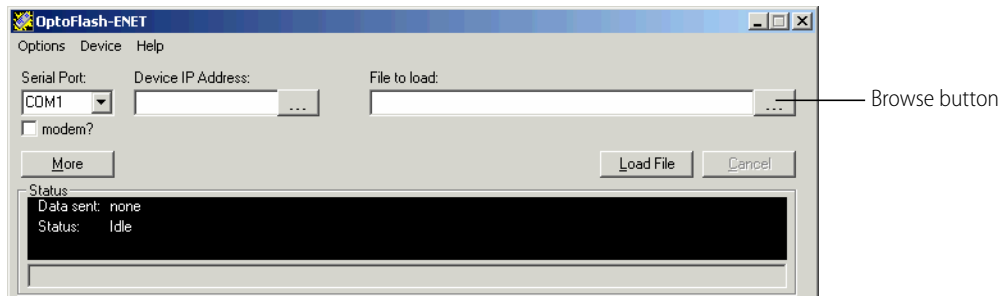

8. If you are using a serial connection to the M4SENET-100, choose the computer's Serial Port from the drop-down list and skip to [step 10](#).
9. If you are using modems to communicate with the M4SENET-100, check the modem box. If the phone number of the M4SENET-100's modem is shown, go on to [step 10](#). If the correct phone number is not

shown, choose Options > Change Modem Options. In the dialog box, enter the M4SENET-100's modem phone number and click Close.

**10.** In the File to load field, type the location of the firmware file, or click the browse button to locate it.

**11.** When the correct file appears in the field, click Load File.

The firmware is loaded to the card. The Status area shows its progress.

**12.** When the load is complete, turn off the controller. Remove the serial cable. Put the jumper back in.

*IMPORTANT: Make sure you put the correct jumper back in the card! The controller will not respond unless the card's Boot to Kernel/Loader jumper is in.*

**13.** Carefully reinstall the card and its cover plate. Turn on the controller.

If you have any difficulty obtaining or downloading new firmware, contact Opto 22 Product Support. See [page 1](#) for contact information.

## SPECIFICATIONS

The following table shows specifications for the M4SENET-100 interface card:

Card type	Ethernet NIC, communication coprocessor
Transports supported	TCP/IP
Maximum sessions	128 total, up to 128 for Ethernet I/O, up to 32 for host or peer
Communications	Ethernet: 10Base-T or 100Base-TX Auxiliary port: RS-232C (for maintenance and firmware downloads)
Data rate	10 or 100 Mbps auto-detected on Ethernet 19.2 Kbps or software selectable on serial port (maximum 115.2 Kbps)
Cable type	Solid unshielded twisted pair, Category 5 recommended for 10 Mbps and required for 100 Mbps
Maximum distance	100 meters from hub to node for single segments
Connectors	One RJ-45 Ethernet and one five-position Phoenix type for serial port
Current draw	1.00 Amps
Jumpers (internal)	Boot to kernel/Boot to loader Normal operation/Restore factory defaults
Temperature	Operating: 0° to 70° C Storage: -40° to 85° C
Humidity	0 to 95% humidity, non-condensing

### LED Descriptions

The following table describes LEDs on the cover plate of the M4SENET-100. See the next page for a diagram of the cover plate.

LED	Description	LED	Description
ETD	Ethernet—Transmit Data	ERD	Ethernet—Receive Data
ACT	Network Activity	FD	Full Duplex Mode
10MB	Ethernet Link Detection at 10 Mbps	100MB	Ethernet Link Detection at 100 Mbps
FLT	Microprocessor Fault	5VB	5-Volt Fault
3VB	3-Volt Fault	RUN	Normal Operation
STD	Serial—Transmit Data	SRD	Serial—Receive Data

## M4SENET-100 Cover Plate

The diagram at right shows the cover plate for the M4SENET-100 interface card.

Pinouts for the serial connector are as follows:

Pin	RS-232
1	TX
2	RX
3	COM
4	RTS
5	CTS

For future use

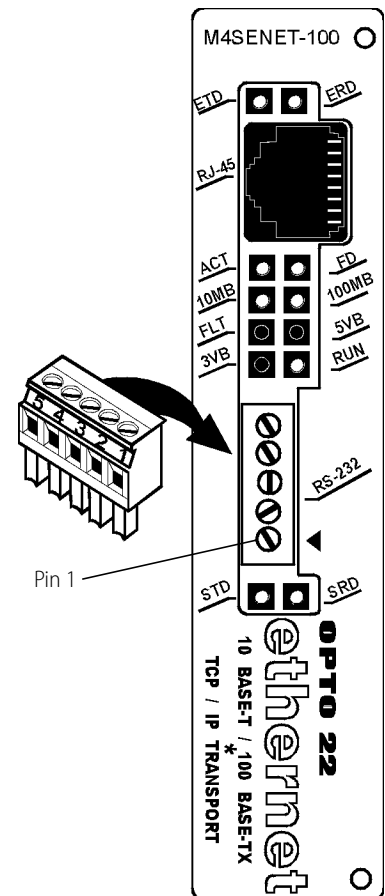

## TROUBLESHOOTING

If you are having difficulty using the M4SENET-100 adapter card, here are some suggestions that may help. If you cannot find the answers you need in this book, contact Opto 22 Product Support. Contact information is on [page 1](#).

### Serial or ARCNET Communication

If you are trying to communicate with the controller via serial or ARCNET and are receiving no response, remember that the controller waits for a startup packet from the Ethernet card (regardless of host jumper settings) before it responds to any communication. Before attempting any communication with the controller, make sure you have assigned a valid IP address to the card (see [page 10](#)) and cycled power to the controller.

Because the controller waits for the card's startup packet and the card performs a quick check after the controller responds, the controller takes slightly longer to boot up than you may expect. If you receive a timeout, wait a second and then try again.

### Ethernet Communication

If you attempt to connect to the card using its IP address and you cannot, first check the following:

- Make sure the controller the card is in has been turned on.
- Verify that you typed in the correct address for the card.

- Make sure the card has a valid IP address and subnet mask. M4SENET-100 adapter cards come from the factory with a default IP address of 0.0.0.0, which is invalid. The default subnet mask is 255.255.255.0. To assign an IP address and subnet mask, see [page 10](#).
- If you are using the M4SENET-100 for host port communication, make sure the M4 controller's jumpers are set for Ethernet (jumpers H0 and H1 both out).
- Make sure you have up-to-date drivers installed on your computer's Network Interface Card (NIC). Contact your system administrator or the manufacturer of the card for help.

### Ping the Card

If you still cannot communicate with the card after you have checked these items, try to reach the card using the PING protocol.

1. Choose Start > Programs > MS-DOS Prompt.
2. At the prompt, type: `ping [card's IP address]`  
For example, type: `ping 10.192.54.40`

**If the card responds,** go to "[Access the Card Using Telnet,](#)" below.

**If the PING command cannot be found,** choose Start > Control Panel > Network. Make sure TCP/IP is configured as a protocol and that an IP address and subnet mask are assigned.

**If you see the message "Destination host route not defined,"** the card probably has an inappropriate IP address and subnet mask. Make sure the IP address and subnet mask on the card are compatible with those on the computer.

**If you see the message "No response from host,"** check the following:

- Are the computer and controller correctly connected? Is the controller turned on?
- Are the IP address and subnet mask on the card compatible with those on the computer?
- Has the card's Boot to Kernel/Loader jumper been removed? This jumper must be in, or the controller will not respond. See the diagram on [page 16](#) for the location of the jumper.

**If you still cannot ping the card,** watch to see if the STD LED is blinking. Count the number of times it blinks and check the possible causes in the table on [page 29](#). If you need help, contact Product Support. (See [page 1](#).)

### Access the Card Using Telnet

Once you know you can ping the card, try to access it using Telnet. You can check card status and diagnose problems. You need to know the IP address of the card.

For diagnostics, it's usually best to connect the card to your PC via a crossover cable. (For help, see ["Connecting Directly" on page 4](#).) Once the PC and card are connected, follow these steps.

*NOTE: These steps assume you are running Windows and accessing Telnet from a command prompt. Other Telnet software will also work if you make sure that local echo is turned off; your steps may be slightly different.*

1. From the Start menu, choose Programs > Accessories > Command Prompt.
2. At the prompt, type `telnet` and the IP address of the M4SENET-100 interface card, and then press ENTER.

For example, if the card's IP address were 10.192.54.87, you would type

```
telnet 10.192.54.87
```

The M4SENET-100 main menu appears:

```

Command Prompt - telnet 10.192.54.185
Opto 22 M4SENET-100
Ethernet Card Menu
=====
<1> Status Read
<2> Status Write
<3> IP Security
<4> Session Information
<5> Task Information
<6> Diagnostic Information

<H> Help
<q> Quit <Disconnect>
=====
Enter Your Selection ->

```

3. To diagnose problems, enter the number of the screen you need. For context-sensitive help in any screen, press H.  
For example, enter `1` to read card status, which shows current TCP settings and any Ethernet errors. For information on TCP settings, see [page 28](#). If Ethernet errors show anything but zero, you may have a network problem.  
For information on Ethernet sessions currently running on the card, enter 4 and see the next section, ["Ethernet Session Information."](#)
4. If you continue to have problems accessing the card, contact Product Support. (See [page 1](#).) If you can access the card using Telnet, go to the Status Read screen and note the loader version and firmware version for the card before you call.

### Ethernet Session Information

For troubleshooting purposes, you can find out information about Ethernet sessions currently running on the M4SENET-100 card. Use Telnet to access the card and enter 4 in the M4SENET-100 Ethernet Card Menu.

Columns in the window are not labelled, but they can be interpreted as follows. Session number is the farthest column on the left; local port is the farthest column on the right.

Column contents	Notes
Session number	128 sessions are possible, numbered from 0 to 127. Enter N to see the next page of sessions.
Session status	0 = Closed 1 = Connecting 2 = Abort connection 3 = Connected 4 = Reconnect 5 = Closing 6 = Unused
Type	Usually TCP
Socket status	1 (0x001) = No file table reference 2 (0x002) = Socket connected to a peer 4 (0x004) = In process of connecting to peer 8 (0x008) = In process of disconnecting 16 (0x010) = Can't send more data to peer 32 (0x020) = Can't receive more data from peer 64 (0x040) = At mark on input 128 (0x080) = Privileged for broadcast, raw 256 (0x100) = Non-blocking ops 512 (0x200) = Async I/O notify 1024 (0x400) = Deciding to accept connection request
Incoming bytes	Number of bytes
Idle timer	In milliseconds
Remote IP address	
Remote port	
Local port	2001 unless you have changed it

### TCP Settings

Retransmit timeout (RTO) refers to the length of time the M4SENET-100 waits while communicating before timing out. The RTO is determined by the **card's** TCP/IP stack, and the stack continually recalculates the RTO based on recent network traffic. If the network becomes busier, for example, the stack automatically adjusts the RTO to a higher value.

If the TCP/IP stack times out while trying to transmit data, it doubles the current RTO and tries again. This process continues for five retries; after that, the **card** stops trying and sends a timeout message.

If you are receiving frequent timeout messages, you can change the TCP parameters using Telnet.

*NOTE: These steps assume you are running Windows and accessing Telnet from a command prompt. Other Telnet software will also work if you make sure that local echo is turned off; your steps may be slightly different.*

1. From the Start menu, choose Programs > Accessories > Command Prompt.
2. At the prompt, type `telnet` and the IP address of the M4SENET-100, and then press ENTER.  
For example, if the **card's** IP address were 10.192.54.87, you would type  
`telnet 10.192.54.87`
3. In the Telnet main menu, enter `2` for Status Write.

*CAUTION: Note the recommended settings. If you set these fields too low, you may not be able to communicate with the **card** at all, even through Telnet, to fix the settings. If this happened, you would have to reset the **card** to factory defaults.*



4. Change the TCP settings as necessary. Use the up and down arrow keys to move the cursor to the field you want to change. Press E to edit the field. Type in the new value and press ENTER.
  - Minimum RTO** sets an absolute minimum value for the RTO. The **card's** calculated RTO will never go below this value.
  - Initial RTO** sets the RTO for the first communication try. Be careful: since all future tries are based on this value, if you set it too low for network conditions, a connection will never be made.
  - TCP Retransmits** sets the number of times the **card** will retry communication. Larger, busier networks need a higher number of retransmits than smaller networks with less traffic.
  - TCP idle session timeout** sets how often (in milliseconds) the **card** allows a session to remain open without any activity. After this time, the **card** closes the unused session. The default is 240,000 milliseconds, or every four minutes.
5. When the values are correct, move the cursor to the Operation Code field. Press E. Type 3 to store the values to flash memory. Press ENTER.
6. To restart the **card**, type 5 in the Operation Code field and press ENTER.  
The new TCP parameters are set.

### Blink Codes

The following table lists possible problems indicated by a blinking STD LED on the M4SENET-100 adapter card. Use the possible workarounds or contact Opto 22 Product Support for help. Contact information is on [page 1](#).

Number of Blinks	Description	Problem	Workaround
2 - slow	Kernel started running.	None	N/A
3 - slow	Kernel CRC check failed; jump to loader.	No valid firmware in flash EEPROM.	Download firmware via serial port.
4 - slow	Loader info area has a bad CRC.	Loader information is corrupt.	Probably a hardware problem. Contact Product Support.
5 - slow	Fatal error (exit).	Firmware or hardware problem.	Contact Product Support.
6 - slow	BootP was successful.	None	N/A
7 - slow	Flash programming failure.	Flash EEPROM chips failed to erase properly or program properly.	Hardware problem. Contact Product Support.
8 - slow	Dual-ported RAM memory test failed. (Memory used to exchange information with controller)	Hardware failure.	No workaround. Contact Product Support.

Number of Blinks	Description	Problem	Workaround
9 - slow	The command processor failed to start.	Usually because the startup handshake with the controller did not succeed within 20 seconds (10 seconds for M4SENET-100 firmware versions prior to 1.3.2.6).	<ul style="list-style-type: none"> <li>• If you can connect to the controller via the card using OptoTerm, then upgrading to the latest firmware should fix the problem. (The time the card waits for the command processor to start was increased to 20 seconds.)</li> <li>• If you still get this blink code with the latest firmware and can connect to the controller with OptoTerm over Ethernet, contact Product Support.</li> <li>• If you can't communicate with the controller over Ethernet using OptoTerm, even with the latest firmware, try plugging the card into a different slot.</li> <li>• Try another card in the same slot. If it works, there is a hardware problem on the first card.</li> </ul>
10 - slow	Sometimes the unit resets.	Area in RAM that's not exercised unless it's under heavy network traffic. M4SENET-100s with firmware version 1.3.x.C or later will give the 10-blink code. Prior kernel versions don't give this indicator.	Hardware problem; no workaround. Contact Product Support.
15 - fast	IP address was cleared.	None	N/A